

1T PIPE ROTATORS SPECIFICATION

MGCR -1



WARNING
READ MANUAL AND INSTRUCTIONS
BEFORE OPERATING
DO NOT OPERATE
IF YOU ARE DRUG OR ALCOHOLICALLY IMPAIRED

CAUTION
DO NOT EXCEED
500 kg. Per Roll
1500 kg. Per Set
Cylinder Sizes
Minimum 1/2" to Maximum 16"

MG WELDING PLANT LTD
MODEL: MW-1
CAPACITY: 1000KG
SERIAL NO: MW1-MAZDS-01
MFG DATE: JUL 2018
VOLTAGE: 110V-1P-50HZ
WEIGHT: 70KG

Q.C
OK

EMERGENCY STOP
ON OFF
POWER SWITCH
DO NOT SWITCH UNDER LOAD
FORWARD REVERSE
MANUAL AUTO

1	Model	MGCR-1
2	Capacity (Loading)	1 Metric Ton
3	Capacity (Turning)	1.5 Metric Ton
4	Vessel Size (Min.)	Φ 115mm
5	Vessel Size (Max.)	Φ 500mm
6	Tyre Type and Size	Polyurethane, Φ10"x 2"
7	Electrical Panel	Yes
8	Control Means	Foot Switch Control Cable 3m
9	Incoming Supply	110 Volt OR 240 Volt
10	Roller Drive Motor	90VDC, 100W
11	Roller Speed	5580mm/min
12	Surface Preparation	Gritblast to SA2.5
13	Painting	Painting
14	Color	RED
15	Qty	2
16	Weight	45kg

Dimensional Drawings MGCR-1

■ Power Roll

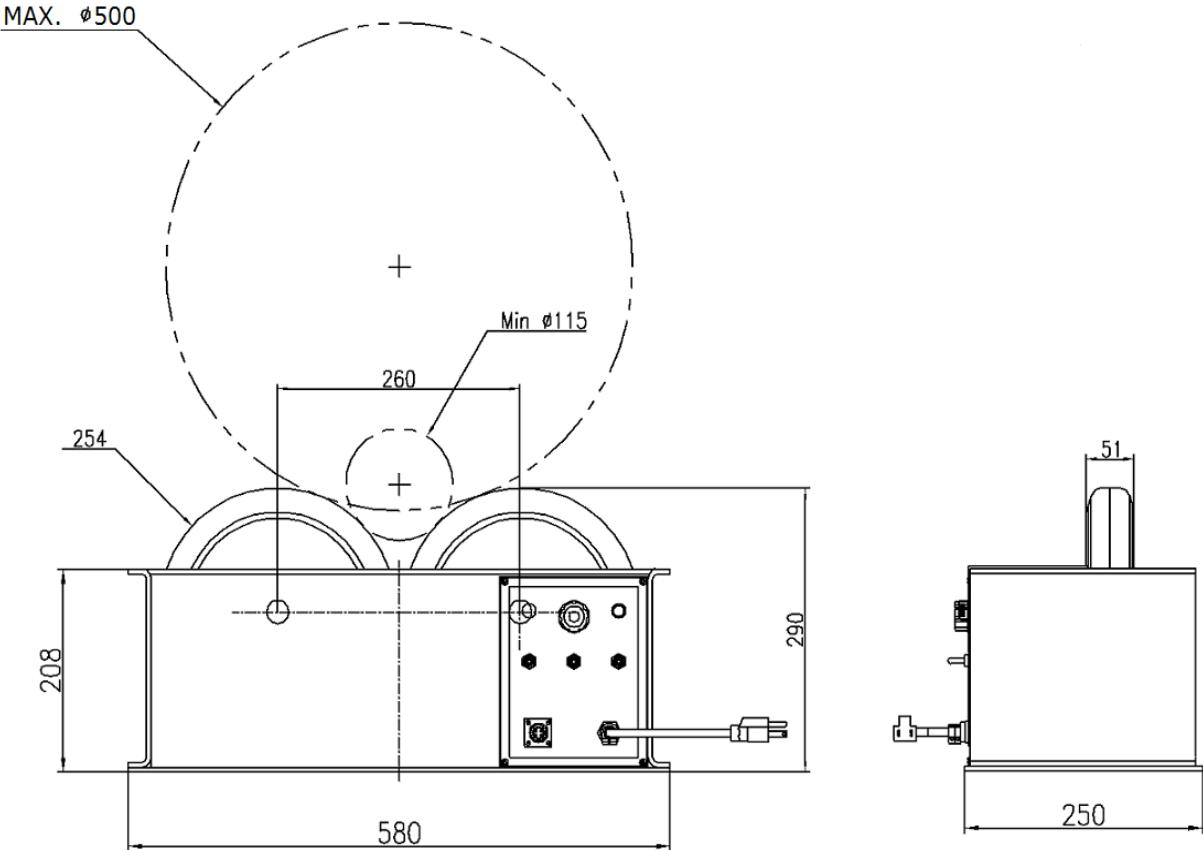

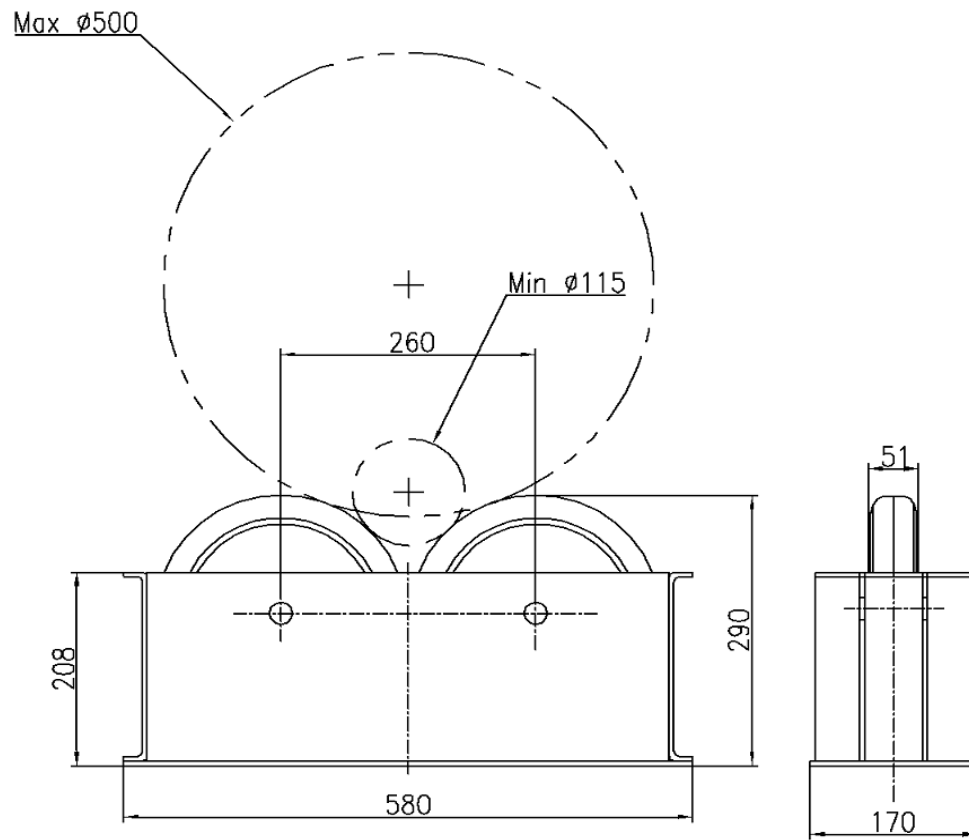

**IDLER
MGCR-1**
