

POS08 80 Kgs Bench Positioner

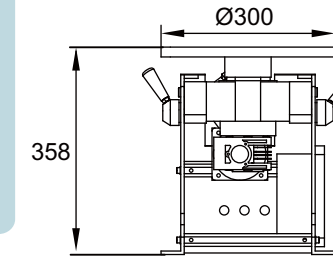

Specification / NO.	POS08C	POS08CS
Power	V1: AC 110V/60Hz/1Ø V2: AC 230V/50Hz/1Ø	V1: AC 110V/60Hz/1Ø V2: AC 230V/50Hz/1Ø
Table Dia	O.D.300mm	O.D.300mm
Table angle	0° - 90°	0° - 90°
Welding current	300A/100%	300A/100%
Table speed	0.7 - 7 rpm	0.7 - 7 rpm
Rotate load	80Kg	80Kg
Rotate torque	90 Kg-cm.	90 Kg-cm.
Start mode	Inch / Timer	Inch / Hold
Rotate the direction	cw / ccw	cw / ccw
Welding time	0 - 60sec	N/A
Arc way of the welder	<input type="checkbox"/> Standard(2 Cycle)	<input type="checkbox"/> Standard(2 Cycle)
Line welder	1st	1st
Stop the brake	Magnetism brake	Magnetism brake
H.F. Protect	95%	95%
Size	L:450mm W:330mm H:360mm	L:450mm W:330mm H:360mm
N.W. / G.W.	33Kg / 36Kg	33Kg / 36Kg

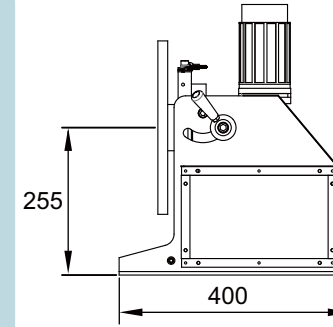

M.G. WELDING PLANT LTD
UNIT 1, VAUXHALL ST,
DUDLEY,
WEST MIDLANDS
DY11TA
TEL : 01384 232121
email: sales@mgwelding.co.uk

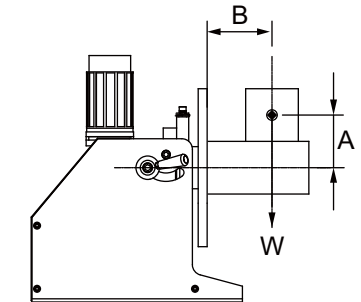

UNIT:mm

POS08C

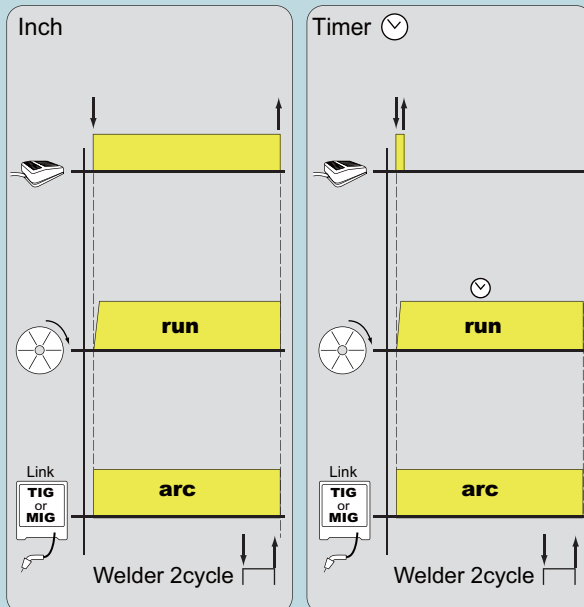

POS08CS

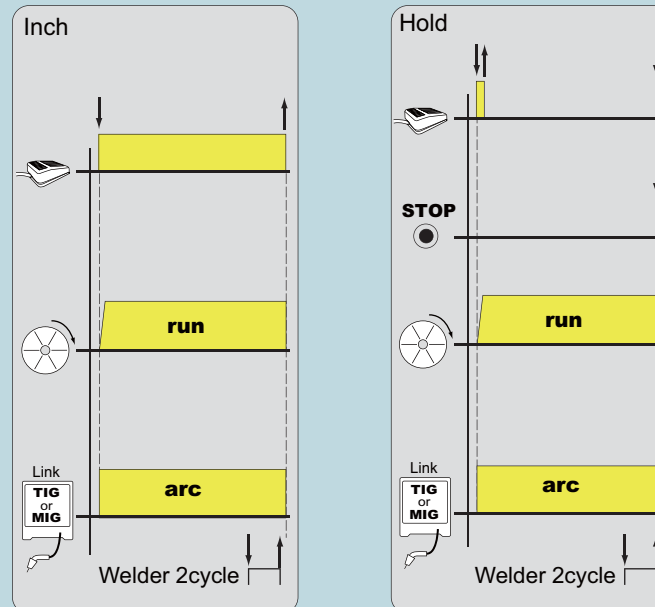

POS08C Positioner Eccentric Load

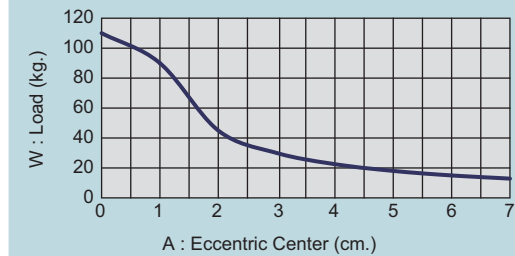

POS08C Center of Gravity

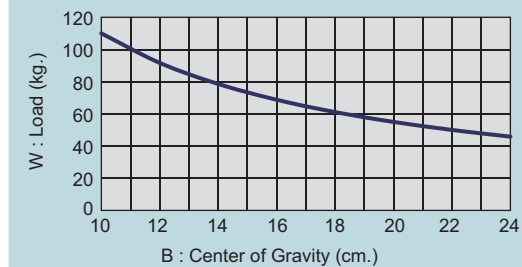

Optional chuck



Self-centering welding chucks - Optional

Type	Can clamp work piece diameter range
200	20 - 200mm.

