

CB 1.2 x 1.2

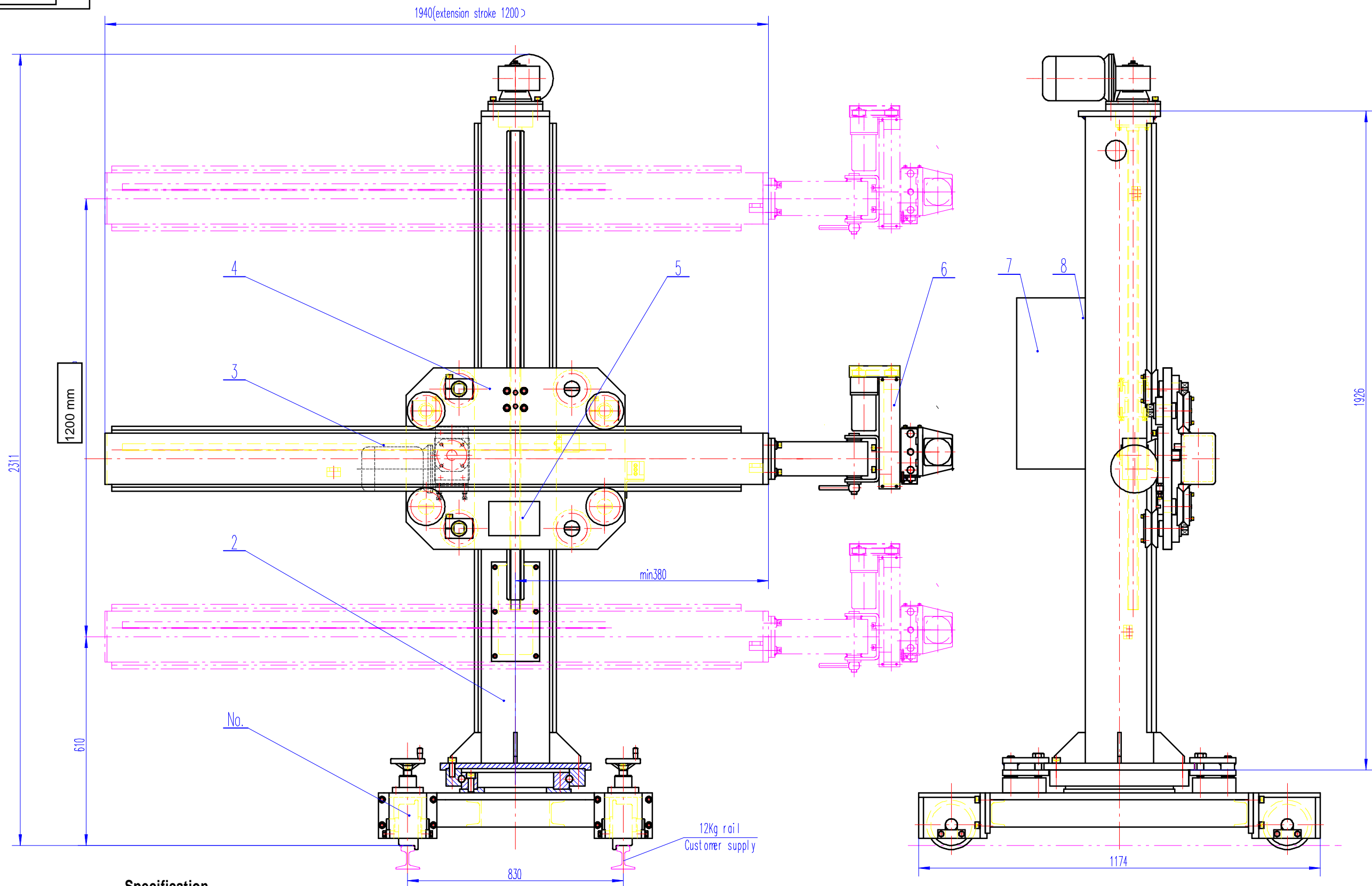

Specification

- 1.Travel and rotate by hand"
- 2.Boom extension speed 1200mm"
- 3.Boom extension speed 1230mm/min"
- 4.Boom extension drive gear and rack"
- 5.Effective vertical stroke 1200mm"
- 6.Boom elevation speed 400mm/min"
- 7.Boom elevation drive screw and nut

8	HC1212-02	Control box bracket	2					
7	HC1212.05-00	Control box	1					
6	WT150B-00	Cross slide	1					
5	HC1212-01	Name plate	1					
4	HC1212.04-00	Saddle	1					
3	HC1212.03-00	Boom	1					
2	HC1212.02-00	Column	1					

1	HC1212.01-00	Trolley	1								
No.	Model	Name	Q'n	Material	Unit Weight(kg)	Gross Weight(kg)	Note				
							CB1212-00				
							CB1.2 x 1.2	Sign	Q'n	Weight	Ratio
									1		
							All pages	Page			
							General Assembly Drawing		M.G.Welding Plant Ltd		

Sign No.	Modify	Signature	Date
Design		Standard	
Check			
Approval		Rectify	
Technology		Date	