

WELD FLUX HOPPERS AND REBAKE OVENS



Flux Holding Ovens

Flux Rebake Ovens

Maintain critical flux specifications with precise temperature control

Utilizes low watt density elements to allow for accurate uniform temperature control

NOTE: Weight and capacity will vary depending on type and density of flux.

Flux Hopper and Rebake Ovens for Submerged Arc Welding

FLUX HOPPERS AND FLUX HOLDING OVENS ASSURE FLUX SPECIFICATIONS ARE MAINTAINED



FLUX HOPPERS

100 lb. (45.3 kg) HOPPER

MODEL GOV 100 FH:

This 100 lb. (45.3 kg) Capacity Flux Hopper is designed for mounting either directly above the welding head or on the welding manipulator to maintain the flux in its original dry state. It is complete with mounting lugs, lift-off loading lid, thermometer, flux level window, flux screen and a flux heating system incorporating 40 watts of low density elements. The temperature is controlled by a thermostat. The temperature range is 100° to 400° F (37.7° to 204.4°C) . All for operation on 115 / 230 volts, 50/60 cycle AC power supply. Weight 27 lb (12.2 kg).

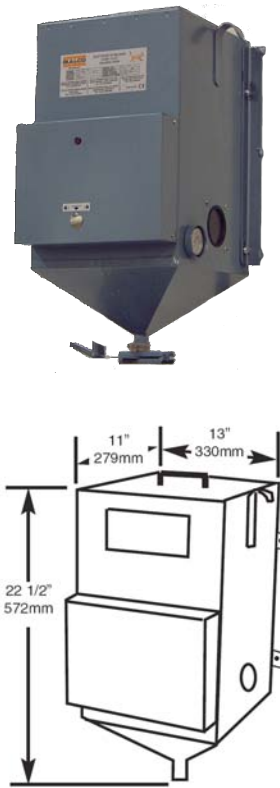

FLUX HOLDING OVENS

MODEL GOV 100 PFD:

This portable 100 lb. (45.3 kg) capacity Flux Holding Oven uses the same flux hopper as Model GOV 100 FH except it is supplied complete with a portable carrier, a 25 lb. (11.3 kg) capacity flux bucket for transfer of the flux to the welding head. Flux bucket gravity feed from a positive lever type valve at the base of the Hopper. The 100 lb. (45.3 kg) hopper can be readily detached from its portable carrier and mounted directly above the welding head or on the welding manipulator. All for operation on 115 / 230 volts, 50/60 cycle AC power supply. Weight 50 lb.



SUBMERGED ARC MOGGY

MODEL GM-02

This SAM® trackless welding carriage can be equipped to produce precision, quality submerged arc or MIG welds. It is guided by adjustable horizontal guide roller assemblies which maintain a set distance from a vertical member or a unique optional "handled" steering device. The unit comes complete with a removable attachment post that holds a wire feed head, flux hopper & valve (submerged arc unit only), wire spool, controls and adjustable weld positioning brackets with horizontal and vertical slides that enable full positioning of the weld gun either behind or beside the carriage.

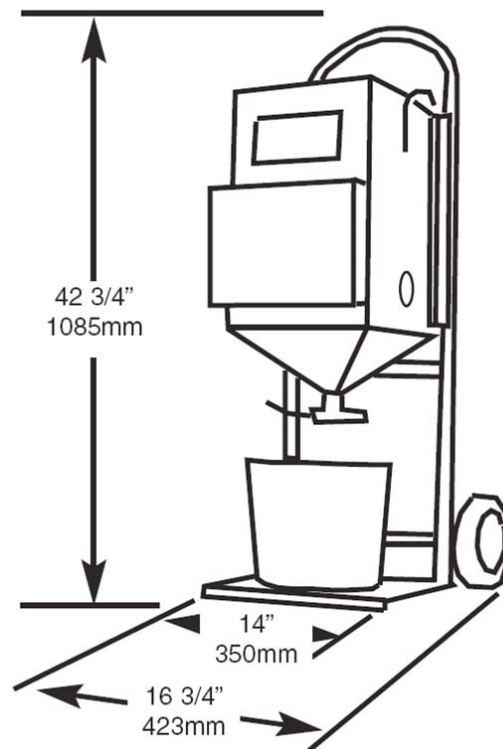

200 LB. HOLDING OVEN

MODEL GOV 200 FD:

This insulated 200 lb. (90.7 kg) capacity Flux Holding Oven is generally located in the storage area and is used to keep the flux in its dry state or to dry out flux that has picked up moisture. It is complete with lifting lugs, and hinged loading lid, thermometer and a flux heating system incorporating 1500 watts of low density elements. The temperature is controlled by a thermostat. The temperature range is 100° to 550°F. (37.7° to 287.7°C) All for operation on 115 / 230 volts, 50/60 cycle AC power supply. Weight 155 lb. (70.3 kg)

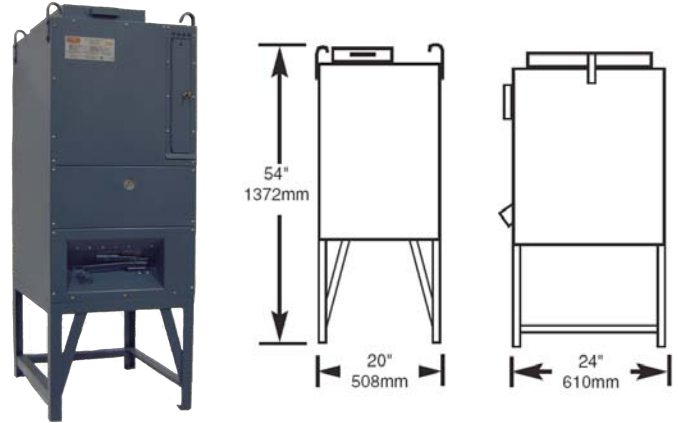

600 LB. HOLDING OVENS

MODEL GOV 600 FD3:

This fully insulated 600 lb. (272.2 kg) capacity Flux Oven incorporates three (3) individual 200 lb. (90.7 kg) hoppers, enabling up to three (3) different types of flux to be stored and dried simultaneously. It is complete with three (3) individual thermometers and a flux heating system incorporating 4500 watts of low density elements. Temperature is controlled by three (3) individual thermostats so that each hopper is individually controlled. Temperature range 100° to 550°F (37.7° to 287.7°C). All for operation on 220 / 415 volt, 3 phase AC power supply. Weight 250 lb. (113.5 kg)

NOTE: All above Ovens can be supplied for operation on 220 volts or 440 volts, single phase power supply. Please consult with manufacturing.



600 LB FLUX BAKE OVEN Model GOV 600 FDH:

This fully insulated 600 lb. capacity high temperature Flux Bake Oven is similar in design to the above Model **GOV 600 FD3**, except incorporating high temperature insulation, high temperature wiring and the flux heating system which incorporates 11,400 watts of low density elements. Temperature range 100° to 850°F. Each hopper controlled by an individual thermostat to provide individual temperature control. All for operation on 220, 440 or 575 volts, 3 phase power supply. Weight 350 lb. *

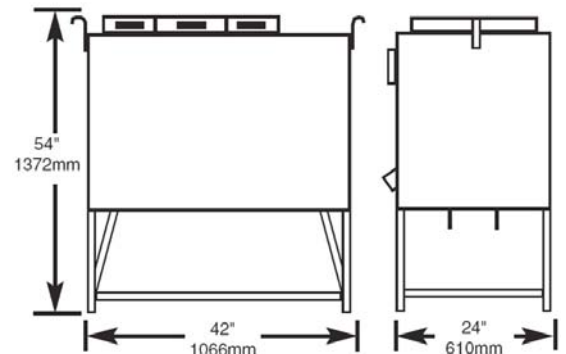

* Voltage must be specified at time of placing order

THE MOST COMPLETE RANGE OF STABILIZING OVENS

PORTABLE WELDING OVENS

These electrode ovens are lightweight but durable. The design makes this oven model easy to carry and easy to load. The welding ovens provide low cost control of welding quality in the shop or at the job site.

Available in 20 lb. (9 kg) capacity and 50 lb. (22.6 kg) capacity models.

MODEL 350



MODEL 125



MODEL 50
50 lb (22.6 kg)
Capacity Electrode
oven with handle
and wheel assembly for
easier portability



MODEL 10A-20

WELDING OVENS: COMPACT IN-SHOP MODELS

The in-shop models are designed to maintain electrode integrity at a higher temperature range. All in-shop models have a recessed control panel for protection as well as removable shelves and thermostat control. These models are available in 125 lb. (56.7 kg), 350 lb. (136 kg) and 1000 lb. (453.5 kg) capacities.

1000 POUND (453.5 kg) CAPACITY HIGH TEMPERATURE ELECTRODE RE-BAKING OVEN

Available in two models, one equipped with an Indicating Control System and the other with an Electronic Digital Programmer Controller.



KAT, KBM, MOGGY, KATBAK & SAM are registered trademarks of Gullco Enterprises Limited

Distributed by:

SPECIFICATIONS ARE SUBJECT TO CHANGE WITHOUT NOTICE. ALL DIMENSIONS ARE NOMINAL

GULLCO		
CANADA - GULLCO INTERNATIONAL LIMITED		
Phone: 905-953-4140	Fax: 905-953-4138	e-mail: sales@gullco.com
U.S.A - GULLCO INTERNATIONAL INC.		
Phone: 440-439-8333	Fax: 440-439-3634	e-mail: ussales@gullco.com
EUROPE - GULLCO INTERNATIONAL (U.K.) LIMITED		
Phone: +44 1257-253579	Fax: +44 1257-254629	e-mail: uksales@gullco.com
AUSTRALIA - GULLCO INTERNATIONAL PTY LIMITED		
Phone: 61 (0)7 3348 5515	Fax: 61 (0)7 3348 5510	e-mail: ausales@gullco.com
INDIA - GULLCO INTERNATIONAL INDIA PVT LIMITED		
Phone: 91-20-6526-0382	Fax: 91-20-2683-6656	e-mail: indsales@gullco.com
CHINA - GULLCO INTERNATIONAL SHANGHAI LIMITED		
Phone: +8621-50460341	Fax: +8621-50463554	e-mail: c.zhang@gullco.com
SINGAPORE - GULLCO INTERNATIONAL LIMITED		
Phone: +65-9385-4468		e-mail: benny.lim@gullco.com
LATIN AMERICA - GULLCO INTERNATIONAL LIMITED		
Phone: 55-11-99485-1336		e-mail: rogerio.macedo@gullco.com
Stuch GmbH & Co. KG Schweisstechnik - GERMANY		
Phone: (02 03) 72 94 95	Fax: (02 03) 72 94 96	e-mail: info@stuch-schweisstechnik.de