

Model	Loading Capacity	Max Torque	Table rpm	Elevation Speed	Table \varnothing	Min Height	Stroke	Max Height	Rotation Motor Power	Elevation Motor Power	Column Height	Column Weight X1
mod.	F - Kg	C1 daN*m	n1 max min ⁻¹	V _{full load} cm/min	D mm	A mm	B mm	C mm	P1 kW	P2 kW	mm	Kg
SLC 20	2.000	300	1	56	400x400	350	1550	1900	0,75	1,85	2.500	600
SLC 40	4.000	350	1	56	600	350	1550	1900	0,55	1,85	2.500	600
SLC 50	5.000	400	0,9	56	750	400	1550	1950	0,55	1,85	2.500	600
SLC 60	6.000	400	0,9	56	750	400	1550	1950	0,55	1,85	2.500	600
SLC 100	10.000	750	1,1	65	900	500	1450	1950	1,1	2,2	2.600	750
SLC 120	12.000	1000	1,1	65	1000	550	1400	1950	1,5	3	2.600	750
SLC 150	15.000	1000	1,1	65	1000	550	1450	2000	1,5	3	2.720	850
SLC 200	20.000	2200	0,9	56	1000	550	1300	1850	2,2	3,7	3.000	1000
SLC 250	25.000	2500	0,9	47	1300	700	1150	1850	3	4	3.100	1200

Stationary Driven Headstock

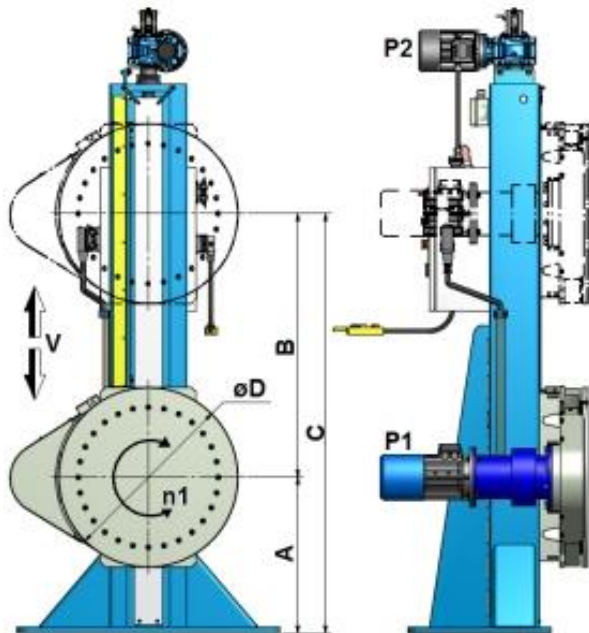

Movable Idler Tailstock

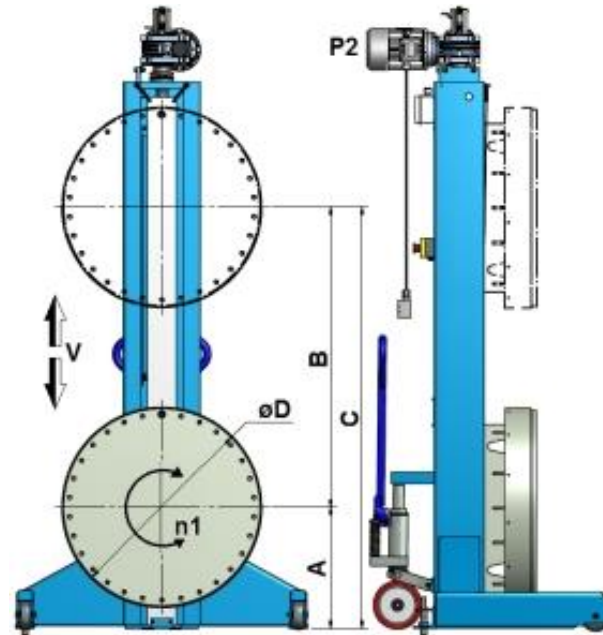

- Higher Columns on customer demand
- Increased load capacity on customer demand
- Powered or manual sub-bases on rails
- Customized table design upon request

